

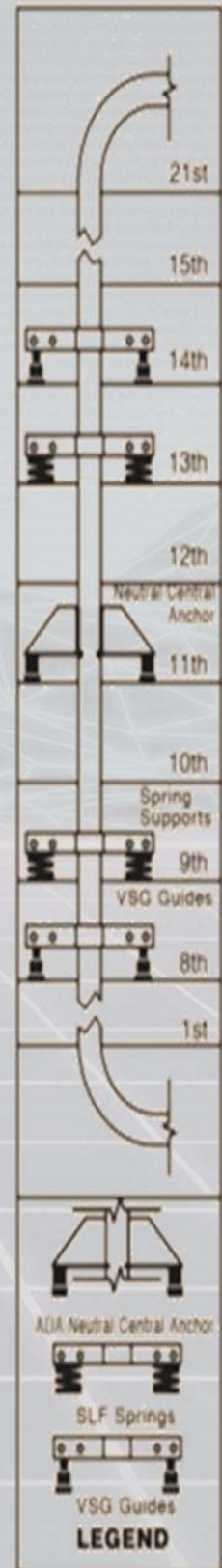

Isolated pipe riser anchors is incorporating multiple spring mounts strategically placed to support the riser and allow expansion and contraction with small and easily calculable load changes. The spring support systems can be designed to utilize a central isolated anchor which remains neutral during operation, or a totally free-floating system with spring support only. If a single anchor is used, it is located as close as possible to the middle of the riser to direct the pipe to expand away or contract towards the anchor point. By locating the anchor in the center of the riser the expansion and contraction at each end is cut in half. The anchor is designed to withstand the “worst case” forces generated when the water weight is removed for maintenance of equipment without the need to access and re-adjust the mountings. As the number and location of spring mounts may vary from one set on every floor for maximum load distribution or they may be spaced at greater intervals. Isolated pipe guides should be used in most systems to maintain alignment of anchored or unanchored spring support systems. Risers can be butt welded when installed to assure integrity. They are easy to install and require no maintenance.

It is an alternative design approach over expansion loop and expansion joint catering for thermal expansion at pipe riser that save space and eliminating joint bursting possibilities.





"MASON" Type ADA

Pipe Anchor

ADA

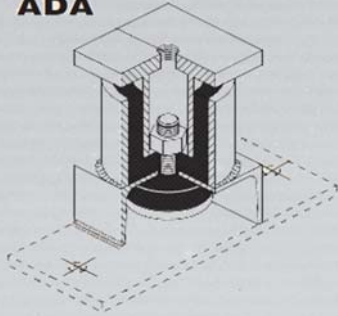

All-directional acoustical pipe anchors, consist of two sizes of steel tubing separated by a minimum 1/2" (12mm) thickness of 60 duro or softer neoprene. Vertical restraint shall be provided by similar material arranged to prevent up or down vertical travel.

Features

- Allowable loads on the isolation material shall not exceed 500psi (3.45 N/mm²)

Applications

- At center of isolated pipe riser system and designed to take up all loadings at riser including water weight to safe guard the whole system

Pipe guides shall consists of a telescopic arrangement of two sizes of steel tubing separated by a minimum 1/2" (12mm) thickness of 60 duro or softer neoprene. The height of the guides shall be preset with a shear pin to allow vertical motion due to pipe expansion or contraction.

"MASON" Type VSG

Riser Guide

VSG

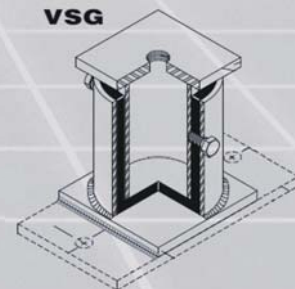

Features

- Guides shall be capable of $\pm 1 \frac{5}{8}$ " (40 mm) motion
- Eliminates the sliding noise created by steel on steel within clamp
- When piping is hot, the Neoprene in the guide is protected , as there is a sufficient temperature differential to the end of the clamp

Applications

- Insulated sliding guide for use at pipe riser guiding