



Vibration isolation measures tackling horizontal thrust force at tunnel ventilation system

High thrust at fan head, axial & centrifugal fans

Fan Heads are cabinets containing a fan and motor and no accessories such as coils and filters. They can develop extremely high thrusts that are equal to the suction area multiplied by the negative head plus the positive pressure multiplied by the discharge area.

These forces act horizontally, opposite to the airflow and about halfway up the cabinet. Since fan heads are light and narrow they tend to shift and overturn with damage to the flexible connections or to the units themselves. Therefore, thrust restraint measures are recommended for all fan heads and for axial or centrifugal fans when the air thrust exceeds 10% of the equipment weight.

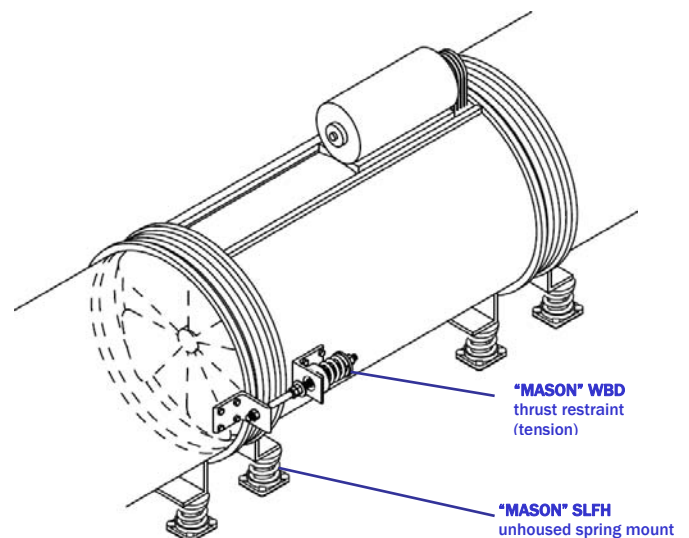

Typical Vibration Isolation measures at tunnel fan head

Use of different thrust restraint measures for compression, tension & directional situation

All "MASON" thrust restraints are pre-compressed assemblies designed to withstand these forces and allow only minor motion. And the series come with 3 different types:

MASON model	Function	Applications at Tunnel ECS
Type WBI	Considered as standard & used in compression across inlet flexible connection on both sides	Axial fan head
Type WBD	Used in tension across the discharge when WBI is impractical	Discharge area of fan
Type WBID	Double acting and allows for air flow reversal	Axial blower

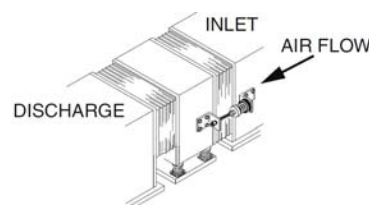

TYPICAL FAN HEAD

Type WBI (for compression situations)

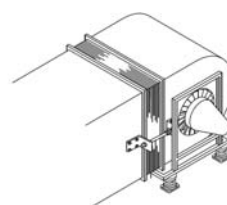

TYPICAL CENTRIFUGAL

Type WBD (for tension situations)

Vibration Isolation case study:

Measures to control horizontal thrust at Tunnel Axial Fan in railway trackside environmental control system



PROJECT DESCRIPTION

Project	: Tsueng Kwan O Line LOHAS Park Station (formerly called "TKO South station")
Project Scope	: Provision of vibration isolation products for power supply, trackside auxiliaries & tunnel ECS in 2007
Client	: ABB (Hong Kong) Limited
Vibration control product supplier	: MASON Industries (Hong Kong) Limited

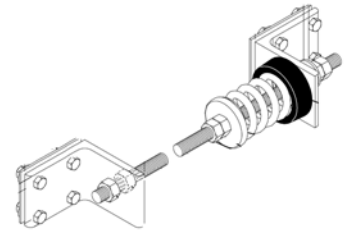

The 12-km long Tseung Kwan O Line is one of the eight lines of the Mass Transit Railway system in Hong Kong. It runs from Hong Kong Island to the town of Tseung Kwan O in Sai Kung, and comprises of 6 stations, namely the Lohas Park, Po Lam, Hang Hau, Tseung Kwan O, Tiu Keng Leng, Yau Tong. Line was put into full operation after the launch of Lohas Park Station in 2007.

ENGINEERING CHALLENGE

Large Horizontal force leads to move of fan and short-circuit of vibration isolation system

Along the trackside there are 13 sets of large axial fan TEF, TSF, TKS and TVF that serving the ventilation inside the TKO line tunnel. These powerful ventilation fans not only working at a large airflow rate, but also offer high pressure head too.

From the MTRC engineer's experience, they found that when these large axial fans are mounted onto free standing vibration isolators (isolation mounts without housing / restraints), the large horizontal force generated at start up of fans would move the fan horizontally and closed the flexible connector between anchored air ducts and connecting fan. It short-circuited the vibration isolation system and voided the whole setup.

It is not an unusual for the above problem encountered. Since the horizontal combined thrust for the fan in concern exceeded 10% of the fan weight. If the spring column alone resists this 10% force, it will lean over about 12% of its rated deflection (i.e. for a 50mm deflection spring, it is 6mm). To eliminate the problem while maintaining the isolation performance of the whole system, thrust restraint mountings were recommended.

Vibration Isolation Product Employed

“MASON” horizontal thrust restraints (model: WBI & WBID)

“MASON” unhused spring mounts (model: SLFH)

Finally, we proposed to install thrust restraint mounting limited the movement of concerned axial fan within 6mm (max) horizontally. See below summarized “Mason” thrust restraint mountings used in this project:

Fan Designation	TKS-TEF	TKS-TSF	TKO-TKS-IMF	TKS-TKO-TVF
Air Flow Rate	33 m ³ /s	27 m ³ /s	60 m ³ /s	60 m ³ /s
Fan Diameter	1,400mm	1,400mm	1,800mm	1,800mm
Total Static Pressure	1,250 Pa	1,150 Pa	1,510 Pa	675 Pa
Fan Weight	1,200 kgs	758 kgs	1,850 kgs	1,700 kgs
Est. Horizontal Thrust (N)	1,924 N	1,771 N	3,843 N	1,718 N
MASON Thrust Restraint Model	WBI-A-310	WBI-A-310	WBID-B-750	WBI-A-310

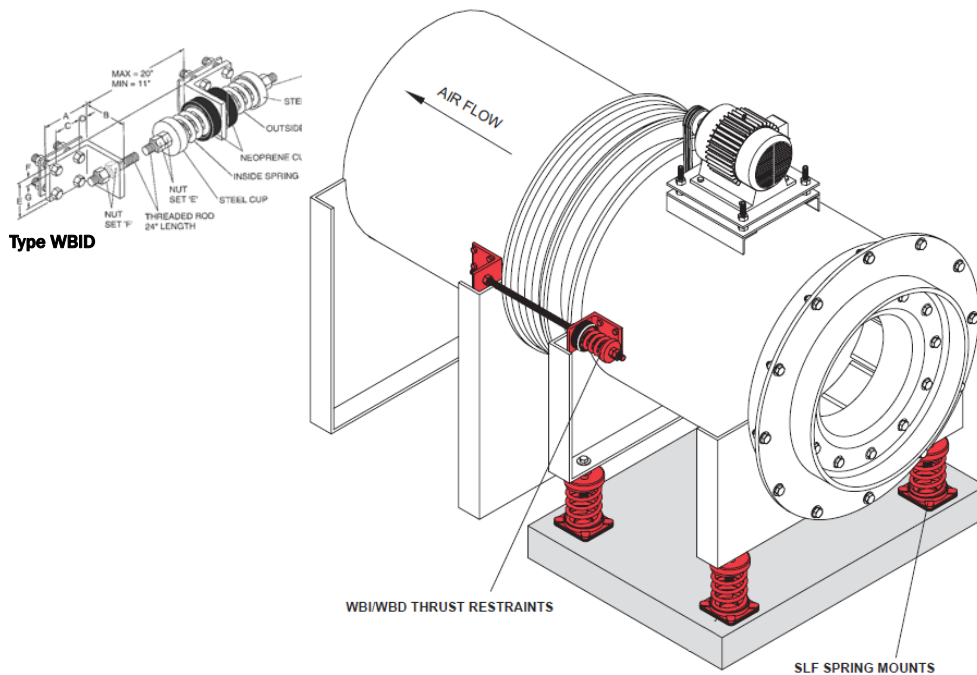

Should you have any queries on above project or other “MASON” vibration isolation products for tunnel ventilation system, please feel free to contact our Sales Engineer, for further discussion at your convenience.

Vibration and Noise Control Specialist



MASON Industries (Hong Kong) Limited
Unit 1710, Floor 17, Fortress Tower, 250 King's Road, North Point, Hong Kong
T: 29679639 | F: 29671772 | email: mail@mason-hk.com | www.mason.hk